

World-class Accessories

From ZKL-house of world-class bearings



ZKL Bearings (India) Private Limited

Address - Diamond Heritage, 15th Floor, Room No - 1511
16 Strand Road, Kolkata - 700 001 (WB) India

Ph no - 033 4084 8531
Email us - kolkata@zklindia.com

Visit us - www.zklindia.com



ZKL Bearings [India] Pvt. Ltd.

Smart Accessories for Smart Bearings

From the house of ZKL

ZKL Value ... Admired across the World & India

ZKL's corporate mission is to achieve excellence in each area of its business and to provide *enduring value* to the customers, worldwide.

ZKL Bearings (India) Private Limited as an exclusive set-up designed to meet the needs of the emerging Asian Economic Powerhouse offers *access to the entire Range of world-class Products, Accessories & Services of ZKL worldwide*. The focus is to provide strategic and creative advantages to customers and users across the Indian sub-continent and surrounds.

Spot the customers' application need and provide the best bearing solution, for it has been the guiding principle behind ZKL's wide and growing range of quality products & accessories.

To get a perfect seat for the bearing, it is very important to ensure proper load distribution which maximizes the bearing life. Ideally, a bearing must have a contact area of more than/atleast 80% on shaft/sleeve as well as in the housing. Hence, the sleeve & the housing quality is of equal importance to that of the bearing.

ZKL SLEEVES

ZKL Adapter Sleeves are used to locate ball & roller bearings with tapered bore. They have the same taper as the bearing bore. Quality manufacturing process through CNC machines ensures above 85% bearing contact and correct seating. ZKL Adapter Sleeves come with Lock-Nut and Lock-Washer and are suited to metric shaft-sizes in multiples of 5mm (prefix H) and in inch sizes in multiples of 1/4th inches (prefix HE). All ZKL Sleeves are made from high grade C20 / C30 steels. A whole range of withdrawl sleeves have also been made an 'of the shelf' item.

ZKL "SNG" SERIES BEARING HOUSINGS

The ZKL SNG series is a new generation bearing housing designed and manufactured to replace and outperform conventional bearing/housing, on all counts. ZKL SNG series is *the right housing for your high-precision bearing*.

Performance indices and benefits of ZKL SNG Series Housings are:

- + Reduced inventory through elimination of multiple housing variants
- + Easy interchangeability (with SNA, SNH, SNL, SNU)
- + Easy installation
- + Higher load carrying capacity
- + Higher rigidity
- + Longer life cycle
- + Competitive pricing

Outstanding features:

- + Fabricated from quality machine castings (grade ASTM-A48, Class 30A or FG-210)
- + All machining on CNC ensures closer tolerances and superior quality
- + Surface / edges – free from high/low spots
- + No casting burrs or blow holes
- + Built-in dimples for easy location of –
 - 1) Oil/grease nipples
 - 2) location for installation of vibration/temperature sensors or monitoring devices
 - 3) Easy-select drainage outlet
 - 4) Locating pins for permanent positioning/alignment
- + Flat machined base for better rigidity
- + Bottom center rib carries higher load
- + Screw driver gap at center height for easy-splitting of housing
- + Special exterior design for greater mechanical strength
- + High tensile bolts to protect housing against shearing & damage of bolts

With special sealing arrangement it can be used with parallel bore spherical Roller Bearings also.

UNIQUE CUSTOMER ADVANTAGES/BENEFITS

ZKL Advantage	Customer Benefit
Advanced design	Takes high speed & load
Higher strength	Longer bearing life
Hi-tech Machining	Longer life/less force for drive-up
Superior roundness/straightness/threading	Easy mounting
Accurate taper angle	Higher speeds
Superior Quality Steel	Lower corrosion
Extra hardness	Better bearing capacity
Thing & Precision Slot	Longer life
Sleeves/Lock-nuts/Washers	Silent running
Improved Packaging	Better grip
Better heat disbursement	Factory-fresh quality
Re-lubrication facility	Lower operating temperature
Better designed seals	No bearing seizure, wider operating temperature
Closer tolerances for Center height problem	Zero bearing contamination
Eye-ball facility	Zero misalignment
Closer bore tolerances	Better handling/lifting of housing
	Avoids bearing creep, reduces operating temperature, improves bearing life

World-class Accessories

From the house of world-class Bearings ZKL

 ZKL Bearings (India) Pvt. Ltd.



ZKL Advantage

Large Warehousing Facility

All India Distributor network

Complete Service Package:

Bearing inspection customer training program, seminars for distributors & users, mounting and dismounting assistance, failure analysis, Service engineering solutions

New Product Introductions - continuous

Customer Benefit

Prompt availability from ready stock

Customers can access ZKL Products & Services wherever they are located

Total Customer / End-User satisfaction

Meeting rising customer expectations

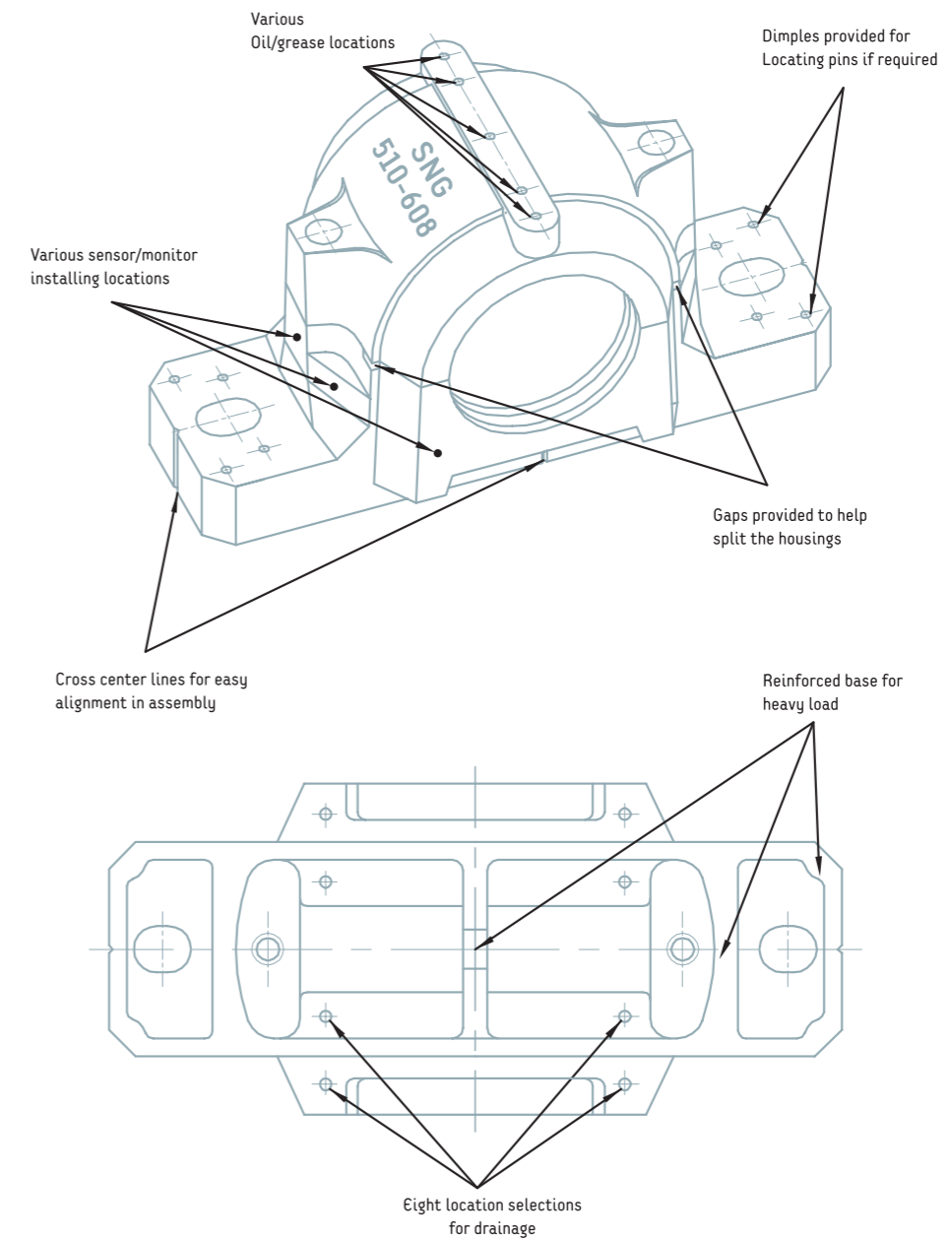
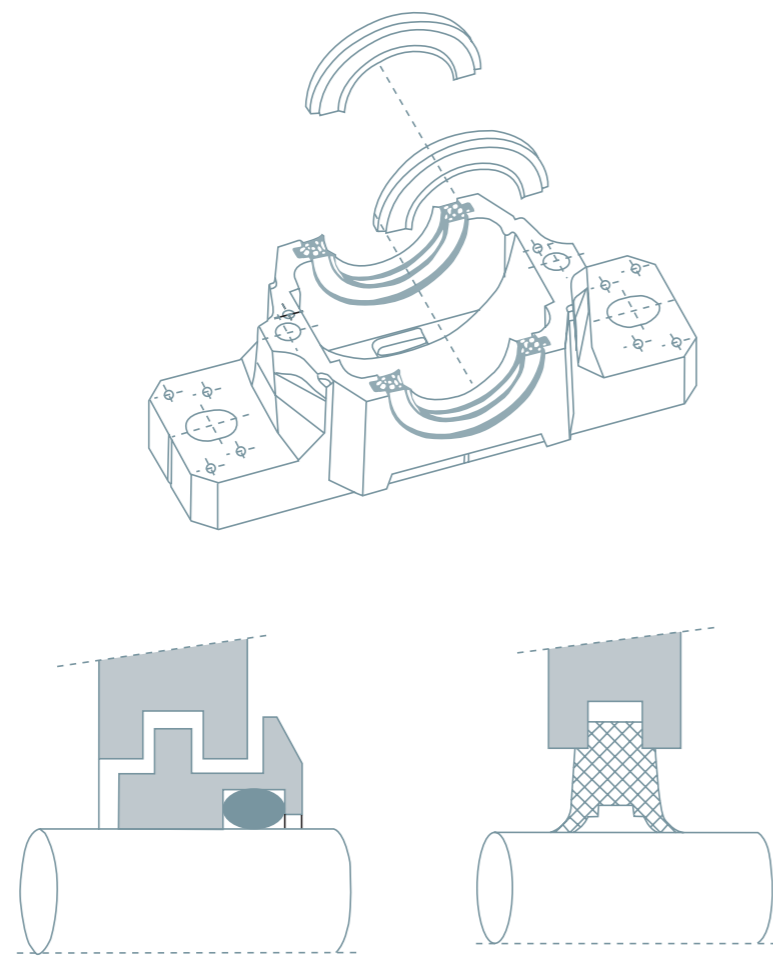

World-class Accessories

From the house of world-class Bearings ZKL



ZKL Bearings (India) Pvt. Ltd.

Specify ZKL when you buy 'Quality'

Item	Bearing Housings: SN 200, 300, 500, 600 Series	Bearing Housings: SNA 200, 300, 500, 600 Series	Bearing Housings: SNG 500, 600 Series (Can replace SNA, SNH, SNL, SNU)	Bearing Housings: Circulation Lubrication SD 3100 Series	Bearing Housings: SAF 200, 300, 500, 600 Series	Bearing Housings: SOFN 20, 300, 500, 600 Series	Adapter sleeves: Metric Sizes of H-200, 300, 2300, 3000, 3100 Series	Withdraw sleeves- AHX-300, 2300, 3100, 3200 Series
Main Features	Cast Iron Housings, horizontally split, fitted with felt/labyrinth seals for grease lubrication	Horizontally split cast iron housing with felt/labyrinth /v-ring seals suitable for Grease/oil circulation	Horizontally split cast iron housing with double lip rubber/labyrinth/taconite/ V-ring seals	Heavy duty, horizontally split of cast iron housing equipped with triple seals suitable for grease/oil circulation librication	Horizontally split Cast Iron housings equipped with Triple/Taconite seals suitable for grease oil lubrication. Can withstand heavy loads and shocks	Split horizontally equipped with labyrinth seals, oil lubricated meant forhigh speed, high operating temperatures	Normally manufactured with a taper of 1:12 on the OD, facilitates less stringent shaft tolerances supplied complete with lock nuts and washers.	Manufactured with external taper, 1:12 and meant for easy dismounting
Bearings	Self aligning ball, spherical roller bearing.	Self aligning ball, spherical roller bearing.	Self aligning Spherical Roller Bearing	Spherical roller bearings of 231 series	Self aligning ball, spherical roller bearings.	Spherical roller bearings	Self aligning ball, spherical roller	Self-aligning ball, spherical roller bearing.
Range : Shaft Diameter	Ø20-160 mm	Ø20-160 mm	Ø30-140 mm	Ø150-320 mm	Ø19.05-242.89 mm	Ø100-260 mm.	Ø20-300 mm	Ø35-340 mm
Lubrication	Grease Lubrication	Grease, Oil Circulation	Grease, Oil circulation	Grease, Oil Circulation	Oil/grease Lubrication	Oil lubricated		
Seals	Felt Seals, Labyrinth Seals	Felt Seals, Labyrinth	Double lip rubber seal/labyrinth seal/V-ring seal/Taconite seal	Triple, Labyrinth Seals	Horizontal labyrinth seals	Labyrinth seals		
Applications	All General Applications	All General Applications	All general & high load condition	For high load, heavy duty applications.	Applications with Heavy/shock loads	High speed, high temperature application	To facilitate easy mounting & to secure bearings having tapered bore on to cylindrical shafts.	For applications to facilitate easy dismounting.
Material	Cast Iron	Cast Iron and spheroidal graphite & cast steel, on demand	Cast Iron (Spheroidal graphite & cast steel on demand)	Cast Iron and spheroidal graphite & cast steel, on demand	Grey Cast Iron, spheroidal graphite CI/Cast Steel on demand	Grey Cast Iron, spheroidal graphite CI/Cast Steel on demand	0.25% Carbon Steel, but for larger sizes of special types of EN8 steel.	0.25% Carbon Steel, but for larger sizes/special types EN8 steel.
Other variants	SSN types	SSNAD, SSNA types	Solid base & four mounting holes	SSD, SDD types	SAFS, SDAF, FSAF Types	SOFNS 2300 series-larger size with	Inch sizes of H 200, 300, and ASK series. oil injection facility (OH) on demand.	Inch dimensions of SK

Note : locknuts (KM) and locking washers (MB), corresponding to above, are offerable from standing range of manufacture and for

sizes beyond will be taken up on demand.